

Vertical Axis Wind Turbine

1000 Watts

VertX 1000-2VX



30 Years Warranty for Linear Performance[#]



12 Years Product Warranty on Materials and Workmanship[#]



22.50% Rated Efficiency









Positive Power Tolerance (-0 / +4.99%)



Low Wind Speed Operation (2 m/s onwards)



TRANSITION TO A BRIGHTER TOMORROW

-  Low Noise & Minimal Vibration Operation
-  Modular Architecture for Easy Maintenance
-  Compact Footprint & Higher Land Utilization
-  Parallel connectivity for higher capacities
-  Patented High-Efficiency Generator Architecture
-  Modular Generator Core for High Torque at Low RPM
-  All-Direction Wind Capture & Hybrid-Ready Integration

COMPANY & PRODUCT CERTIFICATIONS

ASTM E 415:2008, ASTM E 155 Volume -1, BS 1490 Alloy LM24, ASTM E 165/E165 M 2023, IEC 61400-12-1:2005 & ASTM D3359-09, IEC 61400-2:2013
ISO 9001:2015 - Quality Management System
ISO 14001:2015 - Environment Management System
ISO 45001:2018 - Occupational Health and Safety



VERTICAL AXIS WIND TURBINE: VertX 1000-2VX

MECHANICAL CHARACTERISTICS

Electrical Data at STC* & NOCT**

Parameters	Unit	STC
Capacity rating (P_{max})	Watts	1000 W
Max. Power Voltage (V_{max})	Volt	40 V
Max. Power Current in (I_{max})	Ampere	15 A
Open-circuit voltage (V_{oc})	Volt	50 V
Efficiency	%	22.50%
Power Tolerance	Watts	-0/ +4.99
Power Output	-	AC/DC

*STC: 1000W @ 17.5 m/s, Temperature 25°C, Air mass AM 1.25. As per EN 61400-2.

Measurement uncertainty $\pm 3\%$

Cutoff wind speed @ 18 m/s

Parameter	Specification
Generator Type	Modular Low-Torque Axil Flux Permanent Magnet Generator
Generator Dimensions	310 mm (D) x 110 mm (H)
Generator Weight	6.00 kg
Bearing Housing Material	Aluminum Alloy
Turbine Dimensions	445 mm (D) x 1250 mm (H)
Turbine Weight	2.0 kg
Turbine Material	GFRP / Aluminium Alloy
Turbine Stiffener	Aluminium Alloy
Cable	300-400 mm / 4 mm ²
Max Wind Speed Withstand	180 km / hr (Wind Load)
Overall 1000W System weight	35-40 kg

THERMAL CHARACTERISTICS

Parameter	Specification
Operating Temperature Range (T_{op})	-40 to 85 °C

Connectivity

Connector: MC4 Compatible

Parallel Operation: Supported for higher system capacities.

DESIGN SPECIFICATIONS

Power Curve Chart

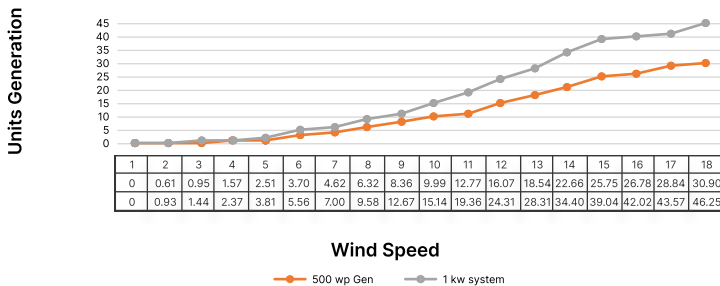

Power Curve Chart

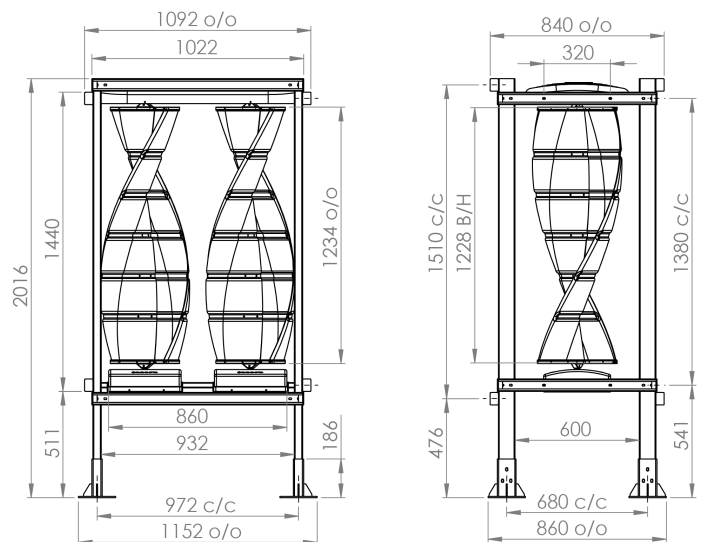
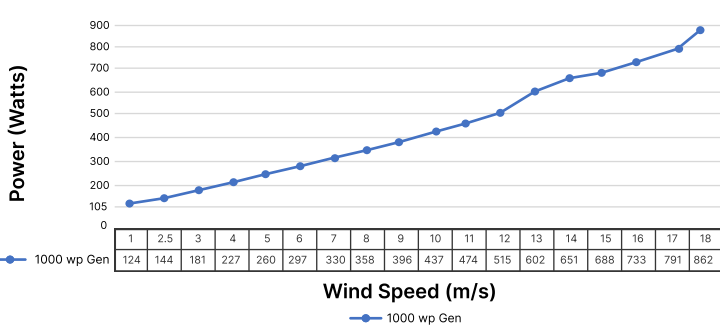

Power Rating Reference

Rated Power Output:

1000W @ 17.5 m/s

As per EN 61400-2 Standards

Disclaimer

Specifications are subject to change without prior notice due to continuous product development and R&D activities. NECON Renewable Energy Gujarat Pvt. Ltd. reserves the right to modify technical data. This datasheet does not form a legally binding contract. T&C Apply.